

Vincent Associates 803 Linden Avenue, Rochester, NY 14625
 web www.uniblitz.com e-mail vincentassociates@uniblitz.com

toll-free 800.828.6972

FEATURES

- 6mm diameter aperture
- Pt-Ir shutter blade, capable of blocking x-ray energy up to 30KeV.
- Exposure repetition rate continuously variable from DC-50Hz.
- Solid state synchronization system included.
- Activated by an electronic pulse through **UNIBLITZ**® patented shutter drive systems.
- Non-resonant design allows instantaneous changes in repetition rate and duty cycle.
- No optical surface when open provides 100% transmittance

The **UNIBLITZ**® XRS6 series is especially designed for x-ray applications. The innovative blade design allows beam extinction $>10^4$ up to 30KeV x-ray energy. The XRS6 shutter is well suited for specific x-ray applications such as x-ray crystallography and can open within 3.2msec at a maximum rate of 50 exposures per second. Precision control and reliability can be expected as with all **UNIBLITZ** products.

This shutter is programmable, and is activated by an electronic pulse generated by Vincent's patented **UNIBLITZ** drive systems. The shutter will follow this pulse, which allows the user to program the exposure duration and frequency.

The XRS6 has a 6mm clear aperture and equipped with the solid state synchronization system. A vacuum compatible version is also available, please consult customer service for further information.

ELECTRICAL

Coil Res.:	12 ohms
Pulse Voltage to Open	+65VDC
Hold Volt.:	+5VDC

MECHANICAL

Operating Temperature	0°C to +80°C
Absolute Max. Frequency of Operation	50Hz
Max. Opening Bounce	15%
Max. Closing Bounce	5%
Number of Blades	1

TIMING

Typical timing values (msec.) using UNIBLITZ drive equipment and measured with UNIBLITZ shutters equipped with .010" PtIr shutter blades.

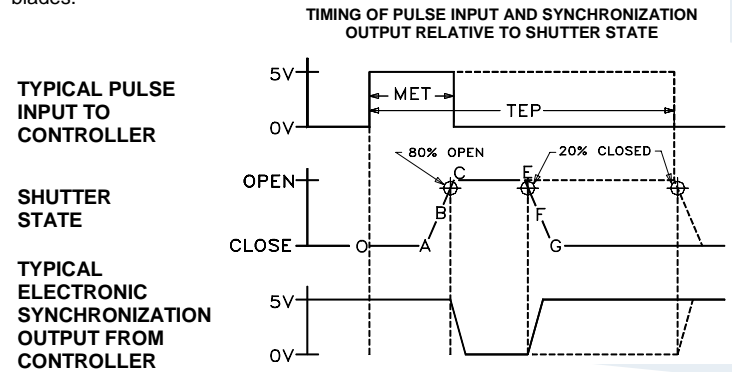

(Timing in msec.)

O-A Delay time on opening after current is applied	1.2
A-C Transfer time on opening	3.2
O-C Total opening time	4.4
B-F Min. equivalent exp. time	5.6
C-E Min. dwell time with min. input pulse	2.0
E-G Transfer time on closing	3.8
A-G Total window time	5.0
MET: Min. exposure time	6.4
TEP: Typical exposure pulse	>6.4

The question regarding enhancement of shutter speed with the application of user supplied lubricants has been repeatedly asked. It is our experience that lubricating the shutter blades will actually slow the shutter down and eventually render the shutter inoperable. UNDER NO CIRCUMSTANCES SHOULD ANY TYPE OF LUBRICANT BE APPLIED TO THE SHUTTER BLADE AREA.

HOW TO ORDER

XRS6S 2 P 0 -100

APERTURE SIZE	HOUSING	BLADE FINISH	SOLID STATE SYNCHRONIZATION	MOUNTING OPTIONS
XRS6S - 6mm	1 - UNCASED 2- #2 CASE	P - .010" THICK PtIr (10% Iridium, 90% PLATINUM)	0 - OMIT SYNC. 1 - SOLID STATE SYNC.	- 21 ZEISS AXIOVERT TYPE - 22 OLD STYLE NIKON TYPE - 23 OLYMPUS TYPE - 24 OLYMPUS TYPE - 26 LEICA TYPE - 27 NIKON TYPE - 28 OLYMPUS IX TYPE - 29 NIKON TYPE - 30 LEICA TRANSMITTED TYPE - 31 NIKON/CONFOCAL TYPE - 100 MOUNTING RING - 105 C-MOUNT ADAPTER (MALE) - 106 C-MOUNT ADAPTER (FEMALE)

UN - HOUSED STYLE

Figure 1

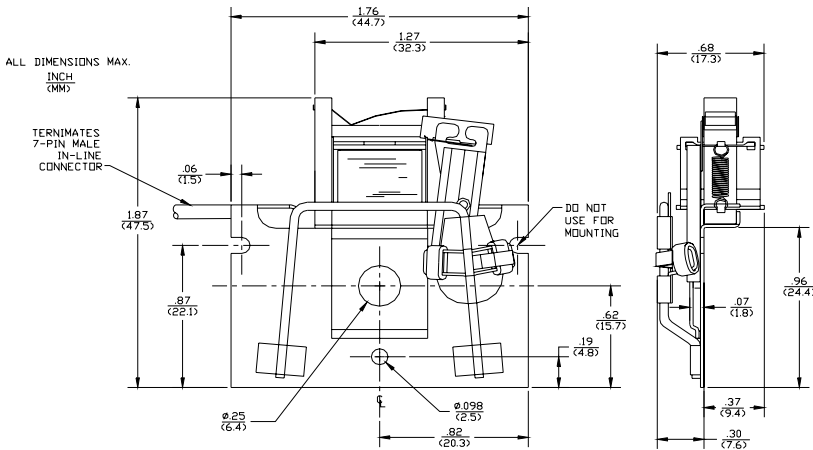

The XRS6 uncased style is the basic configuration of this series and is best suited for OEM applications. Mounting can be accomplished through one 2.5mm slot and one 2.5mm hole below the aperture. The unit terminates to a 7-pin male in-line connector through a six-inch cable assembly.

HOUSED STYLE

Figure 2

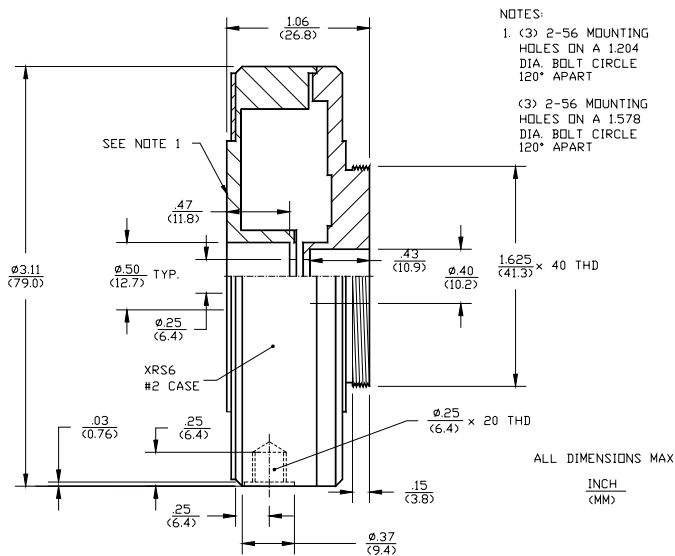

The XRS6 #2 housing style allows a number of mounting configurations. A 1/4-20 threaded hole is provided for post mounting. The 1.625 inch x 40TPI external thread located on the rear side, and the six 2-56 threaded holes located on the front side (see Figure #2 and Figure #3) can be interfaced directly into your application or fitted with a variety of specific mounting options. See "MICROSCOPE & VIDEO MOUNTING SYSTEMS" data sheet for additional information. The unit terminates with a 7-pin male connector.

HOUSING/CONNECTOR

Figure 3

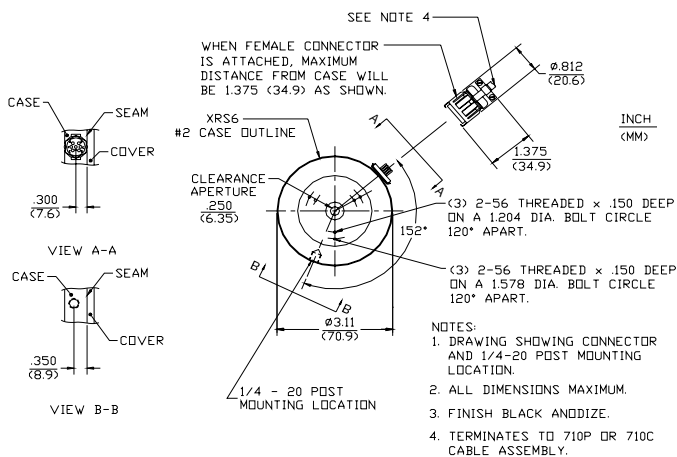

This drawing illustrates 7-pin connector and 1/4-20 threaded hole layout for the XRS6 series #2 housed style.